

Quick Guide

1. Before Installing

Congratulations on purchasing your **AudioCodes 405 IP Phone**! Note: Skype for Business also applies to Lync™. Before you begin using the phone, make sure the following items are included in the shipped box:

- ✓ 405 IP Phone
- ✓ AC power adapter (optional)
- ✓ Cat 5e Ethernet cable
- ✓ Phone base stand
- ✓ Handset
- ✓ Handset cord

2. Physical Description



3. Cabling the Phone



Warning: Prior to connecting power, refer to the *Compliance and Regulatory Information* document at www.audiocodes.com/library.

To cable the phone (refer to the illustration below):

1. Connect the short, straight end of the phone cord to the handset and the longer straight end of the cord to the handset jack on the phone.
2. (Optional) Connect the RJ-9 headset jack to a headset.
3. Connect the RJ-45 Internet port to your LAN network (LAN port or LAN switch/router) with a CAT 5 / 5e Ethernet cable.
4. Connect the RJ-45 PC port to a computer with a CAT 5 / 5e straight-through Ethernet cable.
5. Connect the connector tip of the AC power adapter to the phone's DC 12V power socket and connect the two-prong AC adapter directly to the electrical wall outlet. When the phone powers up, all the LEDs momentarily light up.

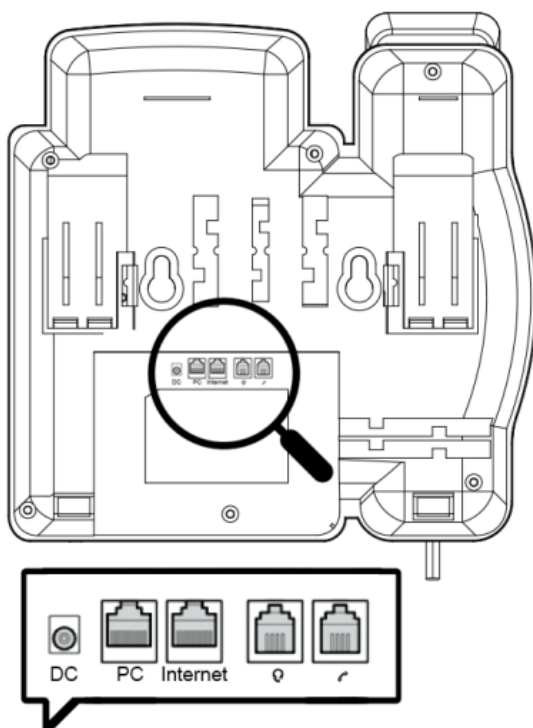

4. Mounting

You can mount your phone on a desktop or on a wall.

- ✓ **Desktop mounting:** Slide the short edges of the L-shaped stand (the prongs) into the phone's two rear slots (see **A** below). Slide the prongs in until they lock.
- ✓ **Wall mounting:** Hook the phone's two rear notches (see **B** below) onto wall mounting screws. Pull out the handset's cradle clip, which is by default in desktop mounting position, invert it, and then push it back in. This is the wall mounting position.

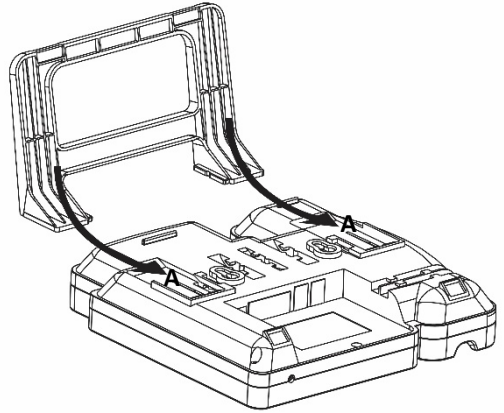
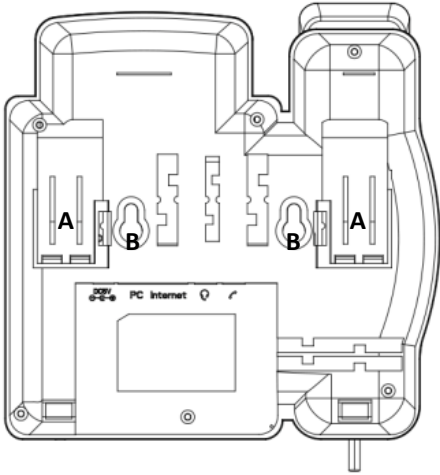

5. Signing in to Lync

- ☞ To sign in with Skype for Business client, see the *405 User's Manual*.
- ☞ To sign in with your phone number and PIN:

1. Press the **Sign in** softkey (when the LCD is in idle mode).
2. Enter your phone number and PIN (default sign-in method), and press **Sign in**.

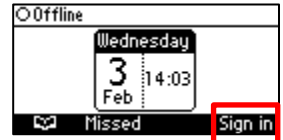

- ☞ To sign in with your username and password:

1. Press the **Sign in** softkey (when the LCD is in idle mode) and scroll down to select **Switch sign-in method**.
2. Enter your sign-in address (SIP address). Press the phone's **1** key to enter a period/fullstop. To enter **@** or **-**, repeat-press it until **@** or **-** is displayed. Press **Clear** to edit. Press the control to scroll across.
3. Scroll down and enter your domain\username, e.g., company\mike. Repeat-press the phone's **#** key to select abc, ABC, Abc, or 123. Repeat-press the phone's **1** key until \.
4. Scroll down and enter your user password – the same you use for PC access – and then press **Sign in**.



- ☞ To sign out: Press the **Status** softkey when the LCD is in idle mode, and then press **Sign out**.

6. Changing your Presence Status

- ☛ **To change your presence:** Press the **Status** softkey (when LCD is in idle mode), scroll to the required presence, and press the **Select** softkey.
- ☛ **To set Skype for Business server to automatically update your presence:** Press the **Status** softkey (when LCD is in idle mode) and select **Reset**.



7. Operating the Phone

- ☛ **To make a call:** Pick up the handset, enter a phone number and then press the **Dial** softkey. To call a phone contact, press the  softkey, select the directory contact and then press the **Dial** softkey.
- ☛ **To transfer a call:** During a call, press the TRANSFER key on the phone, enter the phone number to which to transfer the call, and then press the **Dial** softkey.
- ☛ **To redial a number:** Press the REDIAL key, select a dialed number, and then press the **Dial** softkey.
- ☛ **To answer a call:** Pick up the handset, or press the speaker or headset key.
- ☛ **To place a call on hold and make another call:** Press the  softkey, select **New Call**, enter a phone number and then press the **Dial** softkey. To return to the held call, press the down key and then the **Resume** softkey.
- ☛ **To mute yourself:** Press the mute key. To unmute yourself, press the mute key again.
- ☛ **To forward incoming calls to another phone:**
 1. When the phone LCD is in idle mode, press the **Forward** softkey, scroll down and select **Forward to a Number**.
 2. Enter the number to which you want to forward the calls, and then press the **Start** softkey. To deactivate call forwarding, press the **Forward** softkey and then select **Do not forward calls**.

Notice Information

This Quick Guide describes the quick setup for AudioCodes 405 IP Phone for Skype for Business.

Information contained in this document is believed to be accurate and reliable at the time of printing. However, due to ongoing product improvements and revisions, AudioCodes cannot guarantee accuracy of printed material after the Date Published nor can it accept responsibility for errors or omissions. Updates to this document and other documents as well as software updates can be viewed by registered customers on AudioCodes' Web site at www.audiocodes.com/downloads.

© Copyright 2016 AudioCodes Ltd. All rights reserved.

This document is subject to change without notice.

Date Published: Feb-08-2016

Document #: LTRT-12061

International Headquarters

1 Hayarden Street, Airport City, Lod 7019900
P.O. Box 255, Ben Gurion Airport, Israel, 7019900
Tel: +972-3-976-4000 Fax: +972-3-976-4040

